



US PATENT # 6,675,931 B2



SWS-6.5X (4-Ohm)

SWS-8X (4-Ohm)

SWS-8Xi (2-Ohm)

SWS-10X (4-Ohm)

SWS-12X (4-Ohm)

SWS-15X (4-Ohm)

Installation Reference Guide



The Sound That Will Move You.

Earthquake Sound reserves the right to amend details of the specifications without notice.

Copyright © Earthquake Sound Corporation

Earthquake Sound Corporation • 2727 McCone Avenue Hayward CA, 94545

Phone: 510-732-1000 Fax: 510-732-1095

www.earthquakesound.com

Congratulations are in order... You are now the proud owner of an SWS Shallow Mount Woofer: the most advanced shallow woofer technology to hit car and home audio. The idea is simple: to generate deep bass from the shallowest space. For years, audio manufacturers attempted to reduce the mounting depth of a driver; nevertheless the speaker size/diameter still played a major role in dictating the mounting depth. Approximately, a speaker mounting depth remained to be about ½ the size of the speaker diameter: the larger the speaker the deeper the mounting depth.

Audio, video, and data processing components have gotten better, faster and smaller. This is true except when it comes to speakers design, conventionally designed drivers remain “bulky” in comparison to other audio components. In 1929, Mr. H. Shotwell designed the first “front loaded magnet” driver, it was a small step in reducing the mounting depth of driver. Since then, other audio manufacturers (such as Bose, Harmon and others) made several attempts to reduce the mounting depth of a driver. Nevertheless, the speaker mounting depth remained to be about roughly half the size of the speaker diameter - the larger the speaker the deeper the mounting depth. This “handicap” held true until few years ago when Joseph J. Sahyoun (Vice President, Inventor, and Head Engineer at Earthquake Sound Corporation) started developing the shallow mount woofer system (SWS). The “SWS” presented a radical solution away from the conventional “bulky” speaker design.

The SWS design reduces the mounting depth of a speaker by over 60% without taxing its performance. These numbers look even better as the speaker diameter increases. A conventional 12” woofer has a mounting depth of 6 to 7 inches (for a ± 1” excursion); on the other hand, an SWS-12 performs the same in a little less than 3” of mounting depth. The SWS design allows the installer to use compact enclosures, whereby the mounting depth is about 1.5 times the peak-to-peak excursion. The SWS technology makes the speaker mounting depth “excursion-dependent” and not “diameter-dependent”. Once a target Xmax is set, the mounting depth follows (1.5 times the peak to peak excursion); the Xmax remains independent from the size (diameter) of the speaker. The SWS opens the door for unrestricted bass applications where a conventional subwoofer could never be used.

In home applications, SWS allows the designer to build 12” in wall woofer that moves 2” peak to peak while maintaining a mounting depth of less than 3”. This technology opens the door for home theater designers to squeeze large woofers in very tight spaces / closets, also to do in-wall woofer application. In car applications, rear-deck subwoofer mount - used by manufacturers of luxury automobiles- represents a perfect example of a totally stealth install (using 10”, 12”, 15” SWS). 8” door mount with 1” peak to peak now is possible where mounting depth is a mere 1.5”; with a possibility of using 10” SWS in the doors of larger SUV's.

The aluminum custom-made cone and dust cap are designed to reduce the voice coil temperature by dissipating the heat that builds up in the voice coil. The dust cap is directly fastened to the voice coil aluminum bobbin, it transfers the heat build-up from the bobbin into the cone. Both dust cap and cone act as a giant heat sink to reduce the voice coil temperature and increase its power handling and endurance. The high roll pressed-foam surround is coupled with a propagating spider to allow for extreme excursions with no limitations. The slick shallow basket is coated with black chrome and is shaped with slant edges for easy install in tight spaces.

NOTE: The 2-Ohm SWS-8Xi is designed to replace subwoofer in factory upgraded vehicles, such as BMW's, Corvettes, Mercedes Benz and much more.

Model	SWS-6.5X	SWS-8X/8Xi	SWS-10X	SWS-12X	SWS-15X
Revc. (Ohms)	3.600	3.500	3.700	3.700	3.400
Fo. (Hz)	39.31	30.394	28.477	24.006	21.006
Sd. (msqm)	12.500	22.000	33.000	53.000	89.000
BL. (TM)	4.350	6.210	22.095	10.642	10.956
Qms.	4.192	3.987	5.02	3.56	3.847
Qes.	1.723	0.804	0.51	0.515	1.02
Qts.	1.221	0.669	0.46	0.45	0.65
SPLo. (dB)	77.3	86.7	88.2	89.4	90.4
Vas. (Ltr)	9.94	27.830	51.479	149.612	203.112
Xmax (mm)	15	23	28	31	34

(Xmax Measured In One Direction)

SWS-15X

Actual RMS power varies based on box design and on music played

- Speaker diameter = 15"
- Mounting depth = 3 1/4"
- Cut out mounting hole = 13 3/4"
- Weight = 15Lbs
- Voice Coil diameter = 2.5"
- Aluminum bobbin / wire
- Power rating RMS = 400W
- Power rating MAX = 800W
- Revc = 3.76 Ohms

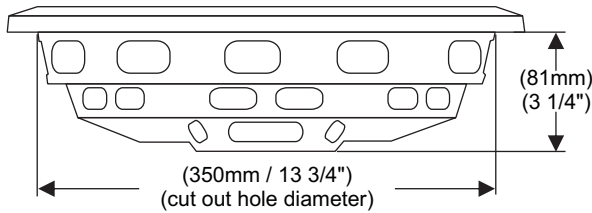

SWS-12X

Actual RMS power varies based on box design and on music played

- Speaker diameter = 12"
- Mounting depth = 3"
- Cut out mounting hole = 11 3/8"
- Weight = 13Lbs
- Voice Coil diameter = 2.5"
- Aluminum bobbin
- Power rating RMS = 300W
- Power rating MAX = 600W
- Revc = 3.76 Ohms

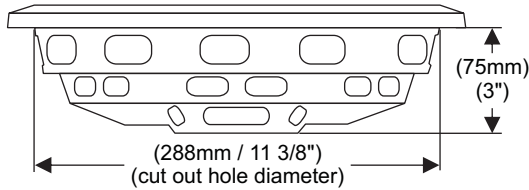

SWS-10X

Actual RMS power varies based on box design and on music played

- Speaker diameter = 10"
- Mounting depth = 2 11/16"
- Cut out mounting hole = 9"
- Weight = 11Lbs
- Voice Coil diameter = 2"
- Aluminum bobbin
- Power rating RMS = 200W
- Power rating MAX = 400W
- Revc = 3.76 Ohms

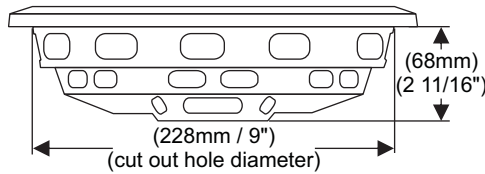

SWS-8X/8Xi

Actual RMS power varies based on box design and on music played

- Speaker diameter = 8"
- Mounting depth = 2 1/8"
- Cut out mounting hole = 7 7/8"
- Weight = 8 Lbs
- Voice Coil diameter = 1.5"
- Aluminum bobbin
- Power rating RMS = 150W
- Power rating MAX = 300W
- Revc = 8=3.76 Ohms / 8Xi=1.76 Ohms

CAUTION:
THE 2-OHM SWS-8Xi
IS FOR FACTORY
UPGRADED VEHICLES
ONLY

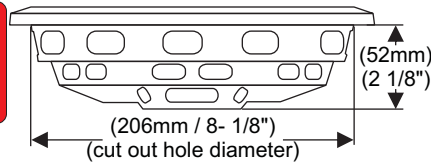

SWS-6.5X

Actual RMS power varies based on box design and on music played

- Speaker diameter = 6.5"
- Mounting depth = 1 3/4"
- Cut out mounting hole = 5 3/4"
- Weight = 5 Lbs
- Voice Coil diameter = 1"
- Aluminum bobbin
- Power rating RMS = 100W
- Power rating MAX = 200W
- Revc = 3.6 Ohms

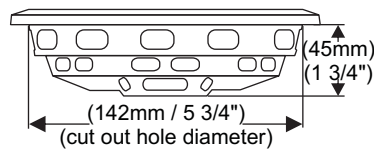

SWS subwoofers are designed to bring bass virtually anywhere in a car: in front doors, rear doors, dash board, center console, under seats, rear decks, and in any space limited mounting depth. The following volumes shown below are created to give you optimized "deep bass from the shallowest space".

In order to match a box volume that best suits your needs, you will need to find out the amount of space that you have to work with, then use the formula below to find out which range you will should be in based on our recommendations.

Choosing an enclosure type that perfectly tailors to your needs can sometimes be a hassle and unfortunately choosing or building the wrong enclosure could potentially destroy the sound quality of your system. The SWS subwoofers deliver truly prenominal bass response from the shallowest of places. And in order to harness their greatness you will need to make sure that your enclosure will be suffice for your application.

Sealed Enclosures:

Do you often turn the bass down on a car or home stereo system because it sounds boomy to you? If you do, a sealed enclosure is an excellent choice, especially if you listen to a wide variety of music. This type of enclosure produces well-defined, strong, but not overpowering bass.

Bandpass Enclosures:

This bass is not really punchy, it's more like a massive, swampy force of low end that powers the music which can be great for some tunes and extremely overwhelming on others. If you prefer the harder stuff (metal, hard rock, industrial) or music with impact bass content (reggae, hip hop) and you like your bass to be LOUD, the bandpass box is a great way to go. And, if your amplifier is lacking in the power department, you'll get the most bang for your buck from this design.

Ported Enclosure:

The ported box is also exceptionally loud, so it will also be a good choice if you have limited power available. If you listen to a wide range of music and if you're always cranking up the bass when you listen to tunes.

CAUTION:

Earthquake Subwoofers are capable of generating high sound pressure levels. You should exercise caution when operating these subwoofer/amplifier systems. Long term exposures to high levels of sound pressure will cause permanent damage to your hearing. Sound pressure levels exceeding 85dB can be dangerous with constant exposure. Set your audio system to a comfortable loudness level. Earthquake Sound Corporation does not assume liability for damages resulting from the direct use of Earthquake amplifiers or other Earthquake products, and urges users to play their music at moderate listening levels.

SOUND LEVEL DBA	DURATION IN HOURS	THE CHART (ON THE SIDE) SHOWS THE U.S. GOVERNMENT'S OCCUPATIONAL SAFETY AND HEALTH ADMINISTRATION (OSHA) REGULATIONS WHICH WERE IN EFFECT AT THE TIME OF THIS PUBLICATION FOR PERMISSIBLE NOISE EXPOSURE, PER 29CFR1910.95, TABLE G-16.
90	8	
92	6	
95	4	
97	3	
100	2	
102	1 - 1/2	
105	1	
110	1/2	
115	1/4 or less	

Finding Box Dimensions For Recommended Enclosure Volumes:

To find the volume best suited for you, you will need to measure the max and min Height, Width and Depth of the area where you to plan to place the sub-enclosure. Then subtract 1.5" each dim to get the internal dims. Now use the internal H, W & D in the formula below to match your dims with one of our recommended ranges.

**Enclosure;
Made With 3/4" Medium
Density MDF**

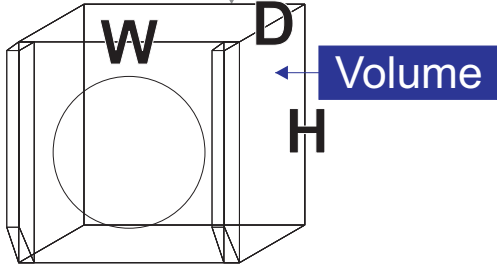

External Dims:
H=10 x W=10 x D=5
Internal Dims:
H=8.5 x W=8.5 x D=3.5

To Get The Internal Dims Simply Subtract
The Total Thickness Of The MDF From The
External Dims;
Which With 3/4" MDF Is 1-1/2"

FORMULA
 $8.5 \times 8.5 \times 3.5 = 0.15\text{cu.ft.}$

CAUTION: In some cases when the enclosure will be placed with the sub facing down or the sub butted up against the back of seat (like the illustration). You will need to either add a grille or use 1" strips of your MDF and place as shown above. This will create an excursion cushion so that it doesn't rub or get damaged.

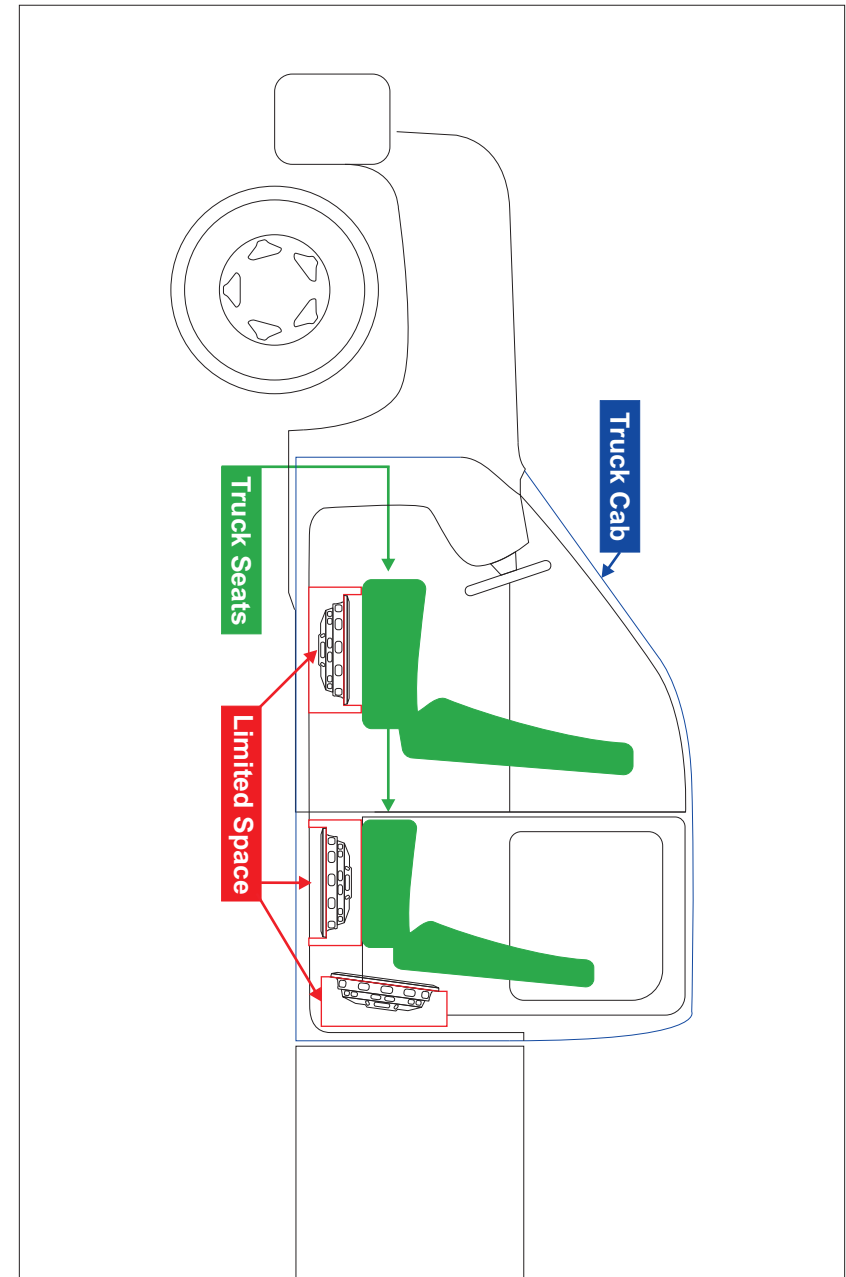

The SWS 6.5 woofer is designed to replace any stock / factory installed 6.5" driver. It brings bass virtually anywhere in a car: in front doors, rear doors, dash board, center console, under seats, rear decks, and in any space less than 2" deep.

Recommended Sealed Internal Volume (8,10,12 & 15" Models)

		(A) →
Minimum: Maximum:	SWS-8/8Xi SWS-8/8Xi	0.19cu.ft. (5.44Ltr) 0.60cu.ft. (16.99Ltr)
Minimum: Maximum:	SWS-10X SWS-10X	0.38cu.ft. (10.76Ltr) 0.75cu.ft. (21.23Ltr)
Minimum: Maximum:	SWS-12X SWS-12X	0.56cu.ft. (15.85Ltr) 1.25cu.ft. (35.39Ltr)
Minimum: Maximum:	SWS-15X SWS-15X	1.20cu.ft. (33.98Ltr) 2.5cu.ft. (70.79Ltr)

Our Examples and Recommendations Are Calculated Assuming That 3/4" MDF Is Being Used

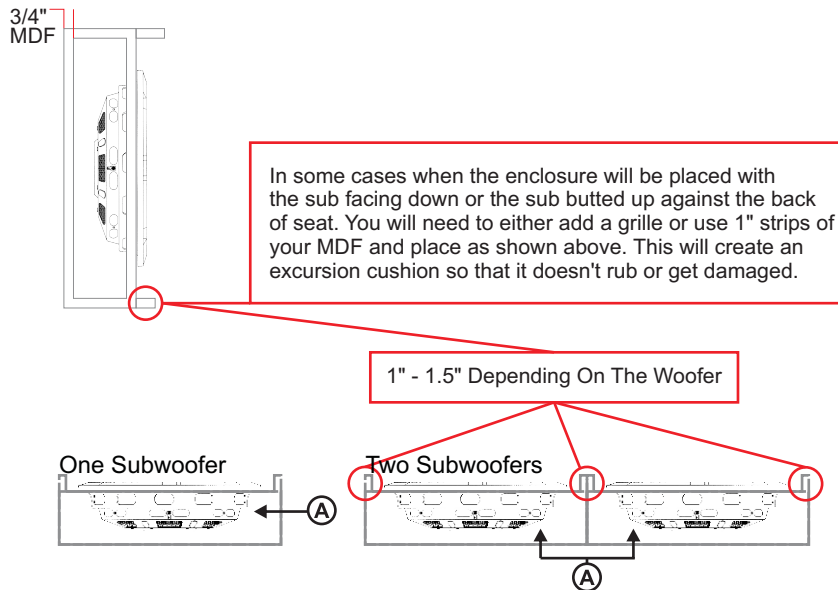

SWS subwoofers will handle crazy amounts of power in any of the recommended enclosures, minimum or maximum. The compact enclosures are best for use in limited-space applications. The larger recommended enclosures will deliver a bit more bass at the lowest frequencies ranges.

SWS-8/8Xi Minimum Sealed Example

External Dimensions: 11" x 11-1/2" x 5"
Internal Dimensions: 10" x 9" x 3-1/2"
Internal Volume: 0.19cu.ft. (5.44Ltr.)

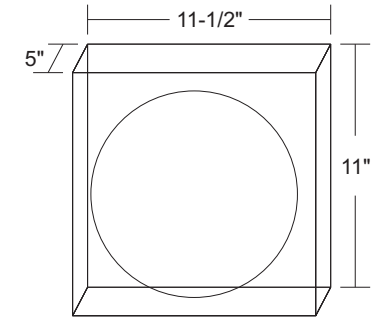

SWS-10X Minimum Sealed Example

External Dimensions: 12" x 17-1/2" x 5.5"
Internal Dimensions: 12" x 16" x 4"
Internal Volume: 0.38cu.ft. (10.76Ltr.)

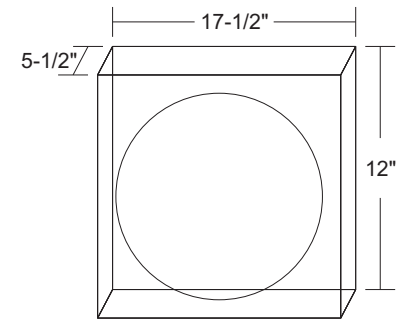

SWS-12X Minimum Sealed Example

External Dimensions: 15" x 19-1/2" x 5-1/2"
Internal Dimensions: 13-1/2" x 18" x 4"
Internal Volume: 0.56cu.ft. (15.85Ltr.)

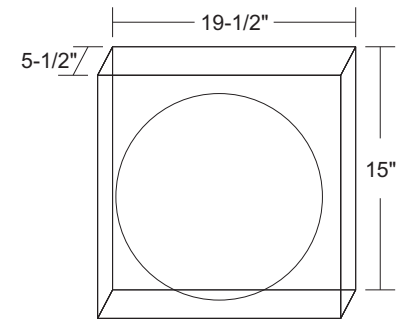

SWS-15X Minimum Sealed Example

External Dimensions: 17-1/2" x 21-1/2" x 8"
Internal Dimensions: 16" x 20" x 6-1/2"
Internal Volume: 1.20cu.ft. (33.98Ltr.)

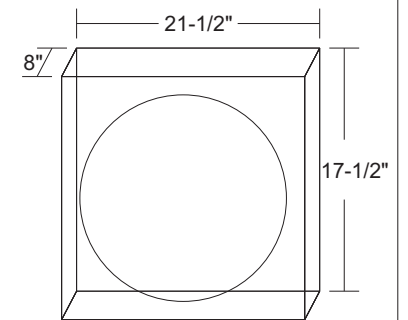

Regarding Your Warranty:

Thank you for choosing Earthquake Sound's line of SWS subwoofers for superior enhancement of your vehicle's audio system from any location. With proper installation and responsible listening, your SWS subs will give you years of phenomenal listening enjoyment.

We strongly recommend you to have your new SWS subs installed by an authorized Earthquake Sound dealer: Installation professionals employed by your dealer have the correct tools and knowledge to install your speakers neatly and successfully. Also, when your new products are installed by an authorized dealer, your product will include a FIVE YEAR LIMITED WARRANTY. If you choose to perform your own installation, your warranty will be subject to limitations. Over the counter authorized dealer warranties may vary from one dealer to the next. Please read the warranty information in its entirety and use good judgment when making these vital decisions.

Five (5) year limited warranty:

Earthquake warrants the original purchaser that all Factory Sealed New Audio Products be free from defects in material and workmanship under normal and proper use for a period of five (5) years from the date of purchase (as shown on the original bill of sale with serial number affixed/written on it). The five (5) year warranty period is valid only if an authorized Earthquake dealer properly installs the product and the warranty registration card is properly filled out and sent to Earthquake Sound Corporation. If a non-authorized party installs the product a ninety (90) day warranty period will be applied.

(A) Five (5) years limited warranty plan coverage guidelines:

- **First year:** Earthquake pays for labor, parts, and ground freight (only in US mainland, not including Alaska and Hawaii).
- **Second year:** Earthquake pays for labor and parts only, customer must pay freight both ways.
- **Third, fourth & fifth year:** Earthquake pays labor only. Customer must pay for parts and freight both ways.

(B) Warning:

Products (sent for repair) that are tested by Earthquake technicians and deemed to have no problem(s) will not be covered by the five (5) year limited warranty. Customer will be charged a minimum of one (1) hour of labor (ongoing rates) plus shipping charges back to customer.

(C) Earthquake will repair or replace - at our option - all defective products/parts subject to the following provisions:

- Defective products/parts have not been altered or repaired by other than an Earthquake factory approved technician.
- Products/parts are not subjected to negligence, misuse, improper use, or accident, damaged by improper line voltage, used with incompatible products, or have its serial number or any part of it altered, defaced or removed, or have been used in any way that is contrary to Earthquake's written instructions.

(D) Warranty Limitations:

Warranty does not cover products that have been modified or abused. Including but not limited to the following:

- Damages to speaker cabinet and cabinet finish due to misuse, abuse, or use of improper use of cleaning materials/methods.
- Bent speaker frame, broken speaker connectors, holes in speaker cone, surround & dust cap, burnt speaker voice coil.
- Fading, deterioration of speaker components & finish due to improper exposure to elements.
- Bent amplifier casing, damaged finish on the casing due to abuse, misuse, or improper use of cleaning material.
- Burnt tracers on PCB.
- Product/part damaged due to poor packaging or abusive shipping conditions.
- Subsequent damage to other products.

A warranty claim will not be valid if the warranty registration card is not properly filled & returned to Earthquake with a copy of the sales invoice.

(E) Service Request:

To receive product/s service, contact Earthquake service department at (510) 732-1000 and request an RMA number (Return Material Authorization), items shipped without a valid RMA number will be refused. Make sure you provide us with your complete/correct shipping address, a valid phone number, and a brief description of the problem you are experiencing with the product. In most cases, our technicians might be able to resolve the problem over the phone, thus eliminating the need to ship the product.

(F) Shipping Instructions:

Product/s must be packaged in its original protective box(s) to minimize transport damage. Shipper claims regarding items damaged in transit must be presented to carrier. Earthquake Sound Corporation reserves the right to refuse product improperly packed. Original bill of sale must accompany product returned for service. We encourage you to include with the package a written description of the problem. Ship product to: Earthquake Sound Corp. 2727 Mc Cone Avenue, Hayward, CA 94545. Ph (510) 732-1000. You are responsible for the cost of shipping the product to Earthquake Sound Corporation.

(G) Disputes Resolution:

All disputes - between clients and Earthquake Sound Corporation - resulting from the five (5) years limited warranty policy must be resolved according to the laws & regulations of the county of Alameda -California.

Warranty Continued On Next Page 

Alternatively you may register your products online at
http://earthquakesound.com/form_reg.htm